

# Concurrent validity and reliability of proprietary and open-source jump mat systems for the assessment of vertical jumps in sport sciences

BASILIO PUEO<sup>1\*</sup>, JOSE M. JIMENEZ-OLMEDO, PATRYCJA LIPÍŃSKA<sup>2</sup>,  
KRZYSZTOF BUŚKO<sup>2</sup>, ALFONSO PENICHER-TOMAS<sup>1</sup>

<sup>1</sup> Department of Sport Sciences, University of Alicante, Ctra. San Vicente, Alicante, Spain.

<sup>2</sup> Institute of Physical Culture, Kazimierz Wielki University, Bydgoszcz, Poland.

*Purpose:* Vertical jump tests are used to assess lower-limb power of athletes in sport sciences. Flight time measurement with jump-mat systems is the most common procedure for this purpose. The aim of this study was to analyze the concurrent validity and reliability of two proprietary systems (Globus and Axon) and an open-source system (Chronojump). *Methods:* A conditioning electric circuit governed by a controlled wave generator is designed to substitute athletes jumping on a physical mat. In order to look for possible differences associated to timekeeping by each microcontroller device, all three systems are fed by the circuit simultaneously. *Results:* Concurrent validity was high for the three systems. Standardized typical error of estimate (TEE) was trivial, according to MBI interpretation as well as perfect Pearson correlation coefficient. Reliability was assessed based on the coefficient of variation of flight time measure, resulting in 0.17–0.63% (0.05–0.12 cm) for Globus, 0.01% (0.09 cm) for Chronojump and 5.65–9.38% (2.15–3.53 cm) for Axon. These results show that all jump-mat system produced nearly identical measures of flight time so they can be considered valid and reliable for practical purposes. In comparison, Chronojump showed the best performance whereas Axon showed enough variability and disagreement to pose a problem in testing elite athletes. *Conclusions:* These experiments show that open-source jump mats are as valid and reliable as their proprietary counterparts at a lower cost. Therefore, practitioners can be confident in using Globus or Chronojump systems to test athletes' jump height because of their negligible errors and Axon system to monitor general population.

*Key words:* athlete, jump, open-hardware, sports, switch, test

## 1. Introduction

In sport sciences, precise measurement of strength and power must be done under conditions delimited by human posture, movement pattern and muscular contraction type. In order to measure lower limb muscular power, sport professionals can use isometric tests, maximum lifting load tests or isokinetic tests, all of which are performed in advanced biomechanics laboratories [19]. Alternatively, the vertical jump height test is a simple and cost-effective method to measure improvements of athlete's performance and as a means of evaluation in physical education [10].

There are three methods for measuring vertical jump [5]. First, through numerical integration of the vertical ground reaction force measured by force transducers subjected to small and short duration impacts in force plates [10], [25]. Second, by Motion Capture, a multiple-camera video technique that can track the kinematics of the center of gravity of the body from standing position to the highest height in the jump [21]. This method can be regarded as the most precise one but it has several drawbacks, such as expensive equipment and a time-consuming process in both preparation and post-processing of takes. Recently, markerless motion capture tries to reconstruct 3D human motion by identifying body segments and

---

\* Corresponding author: Basilio Pueo, Department of Sports Sciences, Computer Science Research Institute, University of Alicante, Ctra. San Vicente, s/n, 03690 Alicante, Spain. Phone: +34 965903400, e-mail: basilio@ua.es

Received: April 12th, 2018

Accepted for publication: July 13th, 2018

joints, either from magnetic or inertial sensors, or from commercial videogame image sensors, such as the Kinect camera [6], mostly used stereoscopic configuration to increase spatial accuracy. Third, jump and reach and flight time measurements are two popular tests among coaches due to their simplicity and ease of use [11], [24]. On the one hand, jump and reach tests are devices that measure jump height by computing the difference between standing height and that reached when athletes use their hand to touch a small vane at the peak of the vertical jump. On the other hand, jump flight can be measured by means of accelerometry, photocell or contact mats that use a basic kinematic equation to calculate jump height by measuring the time that the athlete is in the air, also known as flight time [12], [23].

The latter instruments, jump-mat systems, are most often used by physical trainers and sport scientists because of the accessibility, portability, ease of use and low cost. Jump-mat systems are instruments comprising two devices. The first one is a contact mat made of pairs of equidistant, parallel metallic bars [19]. An improved version of the mat is composed of two parallel, isolated metallic plates [7]. Each pair of metallic pieces (bars or plates) function as an electric switch that closes when an athlete is on the mat and opens by returning to the original position when the athlete is flying and no pressure is applied over the mat. The equivalent circuit is a simple loop containing a switch, which is open or closed if the athlete is off or on the mat, respectively. The second one is a microcontroller to which the mat is attached. In order to check whether the equivalent circuit of the mat is open or close, the port injects a small current and monitors continuity. Then, the microcontroller registers the time in which the athlete takes off (circuit switches from close to open) and lands (circuit switches from open to close). Therefore, flight time  $t$  is the difference between those triggering signals and jump height  $h$  is computed with the formula  $h = t^2 \cdot g/8$ , where  $g$  is the gravity acceleration ( $9.81 \text{ m/s}^2$ ) [8].

Jump-mat systems offer many advantages to coaches, enabling the control of the progress of an athlete along a training program. The device is portable and can be used indoors or outdoors with only a handheld console or laptop. Moreover, jump height assessment can be carried out with instant results, which facilitates a proper feedback. However, although being a simple electrical-contact-operated system, this device is quite expensive. Several companies have launched their own version of the system, such as the Globus Ergotester [19], Axon Jump [1] or Just Jump System [17]. In 2012, an open hardware and free software jump mat system,

called Chronojump [5], was launched. It comprises a mat and a microcontroller that is connected via USB to a computer running the Chronojump analysis software. Since this equipment falls under the free software and open hardware guidelines and that it was launched by a nonprofit organization, the cost of hardware (mat and microcontroller) is significantly lower than the aforementioned companies.

However, the reduced cost are often perceived by sport professionals and scientists as an indicative of poor quality equipment, provided that similar systems are sold by three or four times the cost of Chronojump. The question is similar to that of other fields of science about if free software, open hardware can be a proper alternative to proprietary systems, which have built up a proper reputation and stands for reliable devices.

In this paper, the validity and reliability of free software, open hardware jump-mat systems is assessed by comparison with proprietary systems. To that end, three systems are tested at the laboratory: two proprietary jump systems covering different cost ranges and a free software, open hardware system. The aim is to check the accuracy of flight time measurement for the three systems, provided that flight time is the only variable for computing jump height through the kinematic equation  $h = t^2 \cdot g/8$ . Some authors have conducted similar experiments in which a number of athletes performed trials in different jump mat systems resulting in a large data set [11], [22]. With appropriate data fitting adjustments, they came to conclusions regarding system reliability.

In this paper, our primary aim was to look at possible differences associated to timekeeping by electronic devices (microcontrollers), since mats can be regarded as simply mechanical devices working as switches.

## 2. Materials and methods

Three jump-mat systems were tested: well renowned proprietary equipment Globus Ergotester (Cognè, Italy), cost-effective proprietary equipment Axon Jump (Bioengineering Sports, Argentina) and free software, open hardware equipment Chronojump (Bosco-System, Barcelona, Spain). Since mats are mechanical devices working as switches, all three systems will be tested on timekeeping by their microprocessors with a single input signal by the mat. In order to design the electrical circuit that substitutes each mechanical mat, the equivalent electrical input circuit of

each microprocessor was computed by measuring Thevenin voltage and Norton current appropriately. Thevenin and Norton equivalent circuits are commonly used in electric systems to know the performance of a given circuit without a detailed knowledge of the internal components [9]. Table 1 shows the measured electrical values for the Thevenin voltage  $V_{th}$  and Norton current  $I_N$  and the computed internal equivalent resistance  $R_{th}$ .

Table 1. Thevenin and Norton values for the equivalent circuit of each jump mat system

Instrument	$V_{th}$ [V]	$I_N$ [mA]	$R_{th}$ [ $\Omega$ ]
Globus	5.01	108	46.4
Axon	5.08	136	37.3
Chronojump	4.97	154	32.3

The equivalent circuits consist of a voltage source  $V_{th}$  of about 5 V in series with a resistor  $R_{th}$  from 32.3 to 46.4  $\Omega$ . As it was expected, all systems work in similar conditions, which make it possible to design a conditioning circuit that feeds them simultaneously. In order to simulate the two states that a mat can operate in a transistor will be used in the following modes of operation:

- Saturation, where the transistor acts like a short circuit so current freely flows from collector to emitter as if an athlete is located on the mat.
- Cut-off, where the transistor acts like an open circuit so no current flows from collector to emitter, as if an athlete is the air performing the jump.

Figure 1 shows the experimental circuit with the three jump systems connected to transistor's collector and emitter. A high collector current transistor SS9013 ( $I_{Cmax} = 500$  mA) was selected to handle the sum of the three currents from jump microprocessor. Setting  $V_{cc} = 5$  V,  $R_C = 994$   $\Omega$  (standard value  $R_C = 1$  k $\Omega$ ) and  $R_B = 67.2$  k $\Omega$  (standard  $R_B = 68$  k $\Omega$ ) the transistor is polarized appropriately to switch from saturation to cut-off. In order to stop collector current from deriving to input ports of jump microprocessors, a 1N4001 diode is set in each loop. Therefore, in cut-off mode, each jump microprocessor sees an open circuit, which is interpreted as the athlete to be flying, whereas in saturation mode, each system closes the loop with  $V_{th1} = V_{th2} = V_{th3} \cong 5$  V and  $I_N \cong 398$  mA. Considering a small drop of voltage in each diode, the latter current is even lesser in practice. Although jump microprocessors are designed to work with lower current, this value poses no problem for the time-keeping and for the transistor due to its high current characteristic.

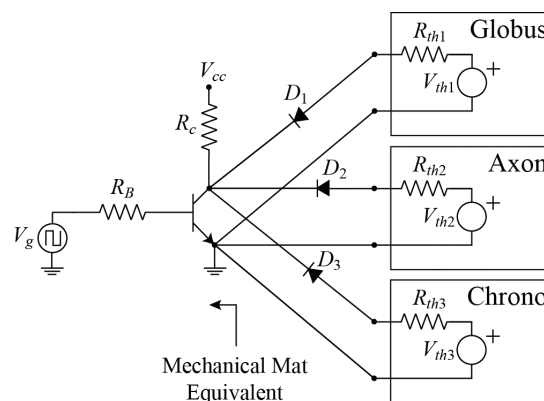

Fig. 1. Experimental circuit to simulate a user-controlled jump mat

To switch between these two modes of operation with precision, an arbitrary function generator Sony Tektronix AFG320 was connected to the base through  $R_B$  with an output amplitude of  $V_g = 5$  V. The selected waveform was a single pulse mode, manually triggered, of a square wave of 1 Hz at different pulse duty cycles to simulate different flight times. As the estimated range of jump heights is 5 to 45 cm, the minimum and maximum flight times can be computed through the kinematic equation [13], resulting in 201 to 605 ms. Outside these values, the microprocessor may respond properly, but the useful range for coaches and scientists is that of real jump heights. Therefore, five flight times: 200, 300, 400, 500 and 600 ms were measured as representative values of a broad range of real life jump heights: 4.9, 11, 19.6, 30.6 and 44.1 cm, respectively. To set the square waveform, the following duty cycles were established: 20%, 30%, 40%, 50% and 60%. A digital oscilloscope Tektronix TDS3054C was also used to detect these waves and measure each flight time through their automatic pulse width measurement feature with 0.1 ms sensitivity. Each flight time was measured 50 times for the three systems simultaneously, resulting in a total of 250 values for each jump system. Oscilloscope pulse widths were also collected to control the accuracy of the wave generator output.

### Statistical analysis

In order to assess validity and reliability of the instrument, all flight times from the three instruments ( $n = 750$ ) were used for statistical analysis. To test the stability of the devices when measuring the 50 flight times of each system range (200, 300, 400, 500 and 600 ms), the coefficient of variation (CV) was used. The CV is a measure of relative reliability that represents the typical error of measurements as a percentage of the mean [3]. All calculations were performed

using Statistical Package for the Social Sciences (SPSS) version 22 (IBM Corp, Armonk, NY).

Additionally, concurrent validity was analyzed through a spreadsheet (Microsoft Office, Microsoft, Redmond, WA, USA), to quantify the relationship between practical and criterion measures [14]. The validity spreadsheet is based on simple linear regression to derive a calibration equation, standard error of the estimate and Pearson correlation. The criterion (digital oscilloscope) was the dependent variable and the practical (each of jump mat systems) was the predictor in consecutive pairwise manner. All measures were log-transformed to reduce bias arising from non-uniformity of error. The standard error of estimate (the prediction error TEE) after standardization (dividing by SD of the criterion) was evaluated using magnitude-based inference (MBI) [15], half the thresholds of modified Cohen scale was used: <0.1, trivial; 0.1–0.3, small; 0.3–0.6, moderate; >0.6, large. The usual scale for correlation coefficients (0.1, 0.3, 0.5, 0.7 and 0.9 for low, moderate, high, very high and nearly perfect, respectively) was used for interpretation of Pearson correlation. Uncertainty in the estimates was expressed as 90% confidence limits. Additionally, calibration equation was used to predict the criterion, given a value of the practical [14]. In order to complement the correlation analysis, Bland–Altman plots were used to visualize the mean of the difference (bias) and the limits of agreement (95% confidence intervals) [4]. Finally, residual-like diagrams of the differences of jump systems and criterion against log-transformed predicted variables

were also used to compare the three devices simultaneously.

### 3. Results

Table 2 shows mean and SD of coefficients of variation CV (%) derived from 50 measurements for each flight time representing the useful range of the instruments. Globus system shows values from 0.17% for 500 ms to 0.63% for 200 ms. Such variation in flight times can be interpreted as variations in jump heights through the kinematic equation, resulting in 0.12 and 0.05 cm, respectively. Regarding Axon system, relative high CV values of 9.38% and 5.65% can be found for 300 and 500 ms, respectively, resulting in 2.15 and 3.53 cm, respectively. Contrastingly, low CV values are found for the remaining flight times: 0.29% for 400 ms and 0.57% for 600 ms, resulting in variations of 0.1 and 0.6 cm, respectively. Finally, Chronojump system shows the best stability of the three devices under test, displaying CV values of 0.01%.

Table 3 shows concurrent validity for each flight time in all ranges of time together (200, 300, 400, 500 and 600 ms) presented as standardized typical error of the estimate and Pearson correlation. Estimated Pearson correlations between each of jump mat systems vs. criterion were perfect for Globus and Chronojump systems, and nearly perfect for Axon system. The calibration equation used to predict flight time for the criterion ( $y$ ), based on value of the practical ( $x$ ), was

Table 2. Reliability of jump mat systems for the five flight times under test expressed as coefficient of variation

Instrument	CV [%] for flight times [ms]				
	200	300	400	500	600
Globus	0.63 ± 1.35	0.52 ± 0.98	0.32 ± 0.68	0.17 ± 0.45	0.29 ± 0.51
Axon	0.01 ± 0.05	9.38 ± 0.38	0.29 ± 2.02	5.65 ± 0.04	0.57 ± 1.34
Chronojump	0.01 ± 0.05	0.01 ± 0.03	n.s.	0.01 ± 0.03	0.01 ± 0.02

Data are means ± SD. n.s. – not significant due to equal means.

Table 3. Concurrent validity each of jump mat systems vs. criterion (oscilloscope)

Instrument	Standardized TEE	MBI interpretation	Pearson correlation
Globus	0.00	trivial	1.00
Axon	0.02	trivial	0.99
Chronojump	0.00	trivial	1.00

TEE – Typical Error of Estimate, MBI – Magnitude-Based Inference where thresholds of modified Cohen scale were used as follows: <0.1, trivial; 0.1–0.3, small.

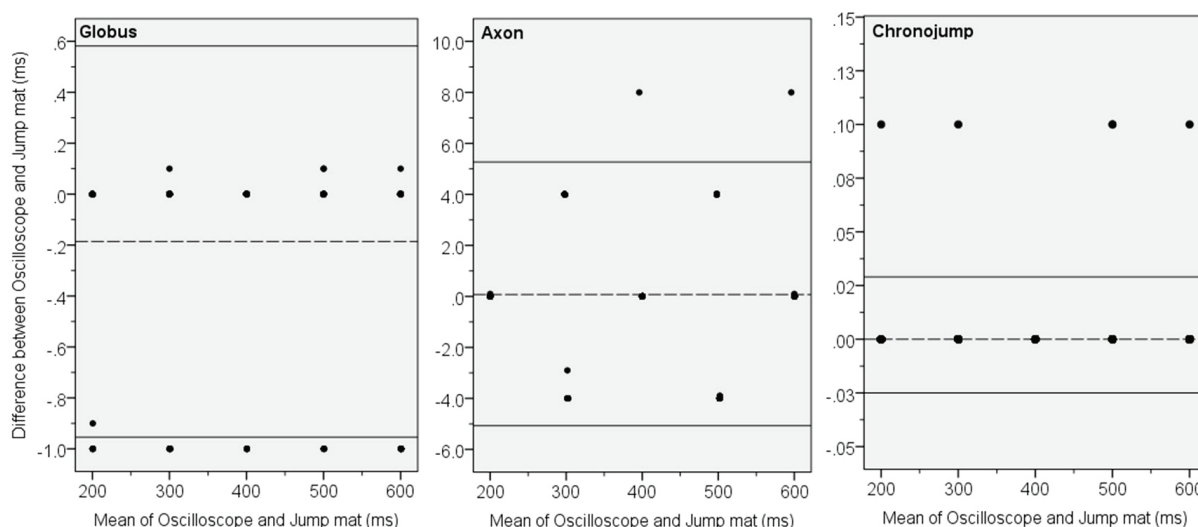

Fig. 2. Differences in jump flight measured by oscilloscope and by jump mat systems against their means. Dashed line represent mean, upper solid line depicts the mean +1.96 SD and lower dashed line represents the mean -1.96 SD

as follows:  $y_{\text{Globus}} = 1.000x + 0.380$  for Globus;  $y_{\text{Axon}} = 0.999x + 0.435$  for Axon and  $y_{\text{Chronojump}} = 1.000x + 0.003$  for Chronojump.

Bland–Altman plots of the three jump systems are presented in Fig. 2, where 95% limits of agreement can be found as continuous lines above and below mean difference as dashed line. For any system to be valid, most of the paired differences may lie within these limits, whereas their mean can help to identify if any system underestimates or overestimates measurements relative to the criterion (bias). Results indicate that Globus system overestimated measurements by 0.186 ms which impact on jump height is about 0.1 mm for the lower jump range (200 ms) and 0.3 mm for the upper jump range (600 ms). It is also of interest to observe whether such bias is constant over the range of values 200 ms to 600 ms. To that end, Pearson correlation between the paired differences and means resulted in  $r < 0.001$ , which indicates no association between them, and, therefore, bias is constant over the range. Almost negligible bias can also be found for the Axon and Chronojump systems (0.07 ms and 0.002 ms) with 0.03 mm to 0.01 mm errors for Axon and <0.01 mm for Chronojump.

The three systems depict paired differences outside 95% limits of agreement. Out of 250 measurements, Globus showed 46 outliers of -1 mm for the five flight time ranges, resulting in errors from -0.5 mm at 200 ms to -1.5 mm at 600 ms. Regarding Axon system, 2 outliers of 8 ms were found, with 0.8 cm for 400 ms and 1.2 cm for 600 ms disagreements. Finally, Chronojump showed 4 outliers of 0.1 ms resulting in errors of 0.05 mm for 200 ms and 0.1 mm for 600 ms. Figure 3 shows percent residuals,

as differences between measured flight time values of the three systems and values predicted by models discussed above, against predicted values.

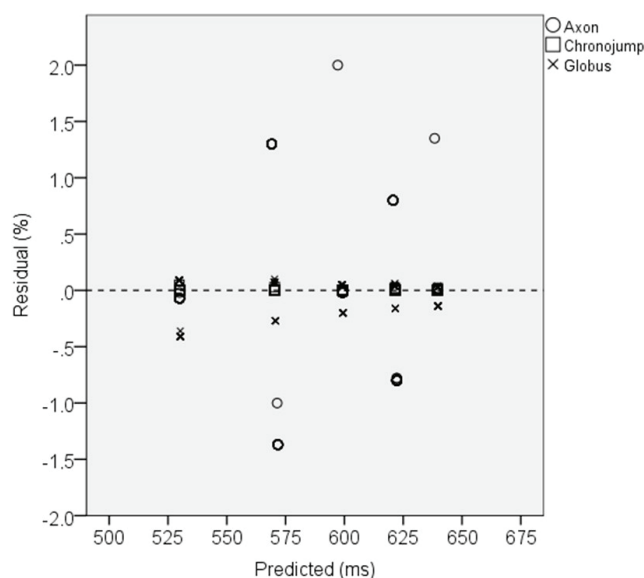

Fig. 3. Residual vs. predicted jump flight measurements for 100log-transformed variables of the three jump mat systems

## 4. Discussion

The aim of this study was to analyze possible variations of timekeeping measurement by microcontrollers of jump-mat systems, as the source of error of such devices, providing that the remaining part of the system is a mechanical mat that behaves as a simple

switch. To that end, a unique had to feed the three jump microcontrollers simultaneously, so that any measure difference might arise. In addition to this, a wide range of jump heights had to be considered to cover the possible nonlinearity in extreme values (shortest and largest flight times). In order to accomplish the above requirements, a wave generator and a conditioning electric circuit was employed to create a controlled system that substitutes a physical mat with athletes jumping on it. The electric circuit was designed to be able to charge multiple jump system microprocessors without electrical interference between them, so that each jump system worked as if a proper mat was being connected. This circuit was then governed by means of a signal generator that created square wave pulses at specific duty cycles that resembled the electrical switching behavior of a mechanical mat in real jumping conditions. To the knowledge of the authors, this is the first validation study with jump systems that isolates the electronic section to look for possible variations between systems for the same mechanical stimuli.

The proprietary system (Globus) showed CV values in the range from 0.17% to 0.63%. Such variation in flight times can be interpreted as deviations in jump heights through the kinematic equation, resulting in 0.12 and 0.05 cm, respectively. Therefore, this variability is very low for typical jump height values, so stability of the device can be considered high. Regarding the second proprietary system (Axon), relative high CV values in the range of 9.38% to 5.65% can be found, resulting in 2.15 and 3.53 cm variations, respectively. Contrastingly, the remaining flight times showed low CV values with little variability in jump heights: 0.1 cm for 400 ms and 0.6 cm and for 600 ms. This amount of variability between consecutive flight time ranges suggests a poor electronic design of the microcontroller which lacks of linearity in its transfer function. Finally, the best stability of the three devices under test was shown by the open source system (Chronojump), with 0.01 to 0.09 mm variation for 200 and 600 ms, respectively. Chronojump was able to give measurements ten times more stable than the best value of Globus and to maintain them for the whole range of practical measures. In spite of the above differences for Globus and Chronojump systems, both are reliable devices in the context of measuring individuals' differences in jump height for practical purposes.

Standardized typical error of estimate (TEE) was trivial for the three systems, according to MBI interpretation, as well as Pearson correlation coefficient showed perfect correlation (Table 3). The latter results

suggest that all devices present perfect agreement and correlation between their outputs and criterion. Only Axon system showed little deviations, compared to Globus and Chronojump.

According to the kinematic equation  $h = t^2 \cdot g/8$ , jump height is proportional to squared flight time. Therefore, the difference between measured flight times through jump systems and oscilloscope criterion would have larger impact for higher values of jump heights. Such trends are easy to interpret if time variables are log-transformed so that any error in the value of jump systems is a percent of the value of the criterion. Therefore, the analysis of percent residuals, calculated as differences between measured flight time values of the three systems and values predicted by the models, against predicted values demonstrated the behavior of the three devices when measuring jump height. The worst case scenario for Globus depicted residuals about -0.5% for 530 ms resulting in -0.4 cm error in jump height. Axon showed residuals of -1.4% for 575 ms and 2% for 600 ms, which impact is -1.1 and 1.8 cm error on jump height. Finally, Chronojump residuals were negligible for the whole measurement range. For the latter estimations, differences (diff) in log-transformed variables were approximated to percent, since  $100(e^{\frac{\text{diff}}{100}} - 1) \cong 100 \text{ diff}$  [14].

A limitation of this study is that three single devices were tested, assuming that their properties will be exactly the same of other copies of the same type of device. However, parameters of electronic parts are often different than their nominal values and, therefore, it may be that Axon system had a combination of parts of the particular system tested leading to such disagreements. Although the specimen tested can be disqualified for jump height assessment in elite athletes, a further study must be conducted to test if other copies of Axon produce similar discrepancies.

## 5. Conclusion

Chronojump has shown to be the most reliable and valid device of the three systems under test. In spite of its low cost, due to the use of free/open licenses and hardware, in comparison to proprietary systems, the system performance is very high. However, with regard to the analytic goal of monitoring changes in athletes' jump height after some training intervention [2], results suggest that the difference in flight time as measured by oscilloscope and any of the three systems under test is expected to lie between reasonable values

for practical purposes. Only Axon system showed relatively high variability up to 3.5 cm and disagreements with respect to criterion in the vicinity of 2 cm in jump height, which can pose a problem in testing individuals' differences in elite athletes [16]. Therefore, practitioners can be confident in using Globus or Chronojump systems to test athletes' jump height because of their negligible errors and Axon system to monitor general population.

## References

- [1] ANDRADE D.C., HENRIQUEZ-OLGUÍN C., BELTRAN A.R., RAMIREZ M.A., LABARCA C., CORNEJO M., ALVAREZ C., RAMIREZ-CAMPILLO R., *Effects of general, specific and combined warm-up on explosive muscular performance*, Biol. Sport, 2015, 32(2), 123–128.
- [2] ATKINSON G., NEVILL A.M., *Statistical methods for assessing measurement error (reliability) in variables relevant to sports medicine*, Sports Med., 1998, 26(4), 217–238.
- [3] BACA A., *A comparison of methods for analyzing drop jump performance*, Med. Sci. Sports Exerc., 1999, 31(3), 437–442.
- [4] BLAND J.M., ALTMAN D., *Statistical methods for assessing agreement between two methods of clinical measurement*, The Lancet, 1986, 327(8476), 307–310.
- [5] DE BLAS X., PADULLÉS J.M., LÓPEZ DEL AMO J.L., GUERRA-BALIC M., *Creation and validation of Chronojump-Bosco-system: A free tool to measure vertical jumps*, RICYDE, Revista Internacional de Ciencias del Deporte, 2012, 8(30), 334–356.
- [6] BONNECHERE B., JANSEN B., SALVIA P., BOUZAHOUENE H., OMELINA L., MOISEEV F., SHOLUKHA V., CORNELIS J., ROOZE M., JAN S.V.S., *Validity and reliability of the Kinect within functional assessment activities: comparison with standard stereophotogrammetry*, Gait and Posture, 2014, 39(1), 593–598.
- [7] BORGES JÚNIOR N.G., BORGES L., DIAS J.A., WENTZ M.D., MATTOS D.J.D.S., PETRY R., DOMENECH S.C., *Validity of a new contact mat system for evaluating vertical jump*, Motriz: Revista de Educação Física, 2011, 17(1), 26–32.
- [8] BOSCO C., LUHTANEN P., KOMI P.V., *A simple method for measurement of mechanical power in jumping*, Eur. J. Appl. Physiol. Occup. Physiol., 1983, 50(2), 273–282.
- [9] CHATZARAKIS G.E., COTTIS P.G., TORTORELI M.D., MALATESTAS P.B., KOLLIPOULOS N.J., LIVIERATOS S.N., *Powerful pedagogical approaches for finding Thevenin and Norton equivalent circuits for linear electric circuits*, Int. J. Elect. Engin. Educ., 2005, 42(4), 350–368.
- [10] GAJEWSKI J., MICHALSKI R., BUŚKO K., MAZUR-RÓŻYCKA J., STANIAK Z., *Countermovement depth—a variable which clarifies the relationship between the maximum power output and height of a vertical jump*, Acta Bioeng. Biomech., 2018, 20(1), DOI: 10.5277/ABB-01058-2017-02.
- [11] GARCÍA-LÓPEZ J., MORANTE J.C., OGUETA-ALDAY A., RODRÍGUEZ-MARROYO J.A., *The type of mat (Contact vs. Photocell) affects vertical jump height estimated from flight time*, J. Strength Cond. Res., 2013, 27(4), 1162–1167.
- [12] HATZE H., *Validity and reliability of methods for testing vertical jumping performance*, J. Appl. Biomech., 1998, 14(2), 127–140.
- [13] HAWKINS J., NOROOZI S., DUPAC M., SEWELL P., *Development of a Wearable Sensor System for Dynamically Mapping the Behavior of an Energy Storing and Returning Prosthetic Foot*, Measurement Science Review, 2016, 16(3), 174–182.
- [14] HOPKINS W.G., *Spreadsheets for analysis of validity and reliability*, Sports Science, 2017, 21, 36–44.
- [15] HOPKINS W., MARSHALL S., BATTERHAM A., HANIN J., *Progressive statistics for studies in sports medicine and exercise science*, Med. Sci. Sports Exerc., 2009, 41(1), 3–12.
- [16] LEGG J., PYNE D.B., SEMPLE S., BALL N., *Variability of Jump Kinetics Related to Training Load in Elite Female Basketball*, Sports, 2017, 5(4), 85.
- [17] MCMAHON J.J., JONES P.A., COMFORT P., *A correction equation for jump height measured using the just jump system*, Int. J. Sports Physiol. Performance, 2016, 11(4), 555–557.
- [18] PIETRASZEWSKI B., RUTKOWSKA-KUCHARSKA A., *Relative power of lower limbs in drop jump*, Acta Bioeng. Biomech., 2011, 13(1), 13–18.
- [19] SANTOS-LOZANO A., NAVARRO R.G., LÓPEZ I., VALLEJO N.G., *Comparison of two systems designed to measure vertical jump height*, RICYDE, Revista Internacional de Ciencias del Deporte, 2014, 10(36), 123–130.
- [20] SHAHBAZI M., *Hybrid 3D dynamic measurement by particle swarm optimization and photogrammetric tracking*, Measurement Sci. Rev., 2013, 13(6), 298–304.
- [21] SKUBLEWSKA-PASZKOWSKA M., MONTUSIEWICZ J., ŁUKASIK E., PSZCZOŁA-PASIERBIEWICZ I., BARAN K.R., SMOLKA J., PUEO B., *Motion capture as a modern technology for analysing ergometer rowing*, Advances in Science and Technology Research Journal, 2016, 10(29), 132–140.
- [22] SŁOMKA K.J., SOBOTA G., SKOWRONEK T., RZEPKO M., CZARNY W., JURAS G., *Evaluation of reliability and concurrent validity of two optoelectric systems used for recording maximum vertical jumping performance versus the gold standard*, Acta Bioeng. Biomech., 2017, 19(2), 141–147.
- [23] STRUZIK A., ZAWADZKI J., *Leg stiffness during phases of countermovement and take-off in vertical jump*, Acta Bioeng. Biomech., 2013, 15(2), 113–118.
- [24] WHITMER T.D., FRY A.C., FORSYTHE C.M., ANDRE M.J., LANE M.T., HUDY A., HONNOLD D.E., *Accuracy of a vertical jump contact mat for determining jump height and flight time*, J. Strength Cond. Res., 2015, 29(4), 877–881.
- [25] WINIARSKI S., RUTKOWSKA-KUCHARSKA A., *Estimated ground reaction force in normal and pathological gait*, Acta Bioeng. Biomech., 2009, 11(1), 53–60.